

# Happy Good Luck Bat by Michael LaFosse

Intermediate

This model, designed for the New York Asia Society in 1984, is the Japanese symbol for good luck. The bat is "happy" because the tapering of the ears in the final step causes it to appear to be smiling. The model is intended to be wet-folded from a half a square of paper, colored identically on both sides, but it may also be folded from a single square folded in half diagonally. A 10" square produces a 5" model. Michael LaFosse has been producing professional quality origami products for over twenty years. For information on purchasing instructional video tapes of this and many other models write him at 170 Margin Street, Haverhill, MA 01832 or Fax him at (508) 373-5503

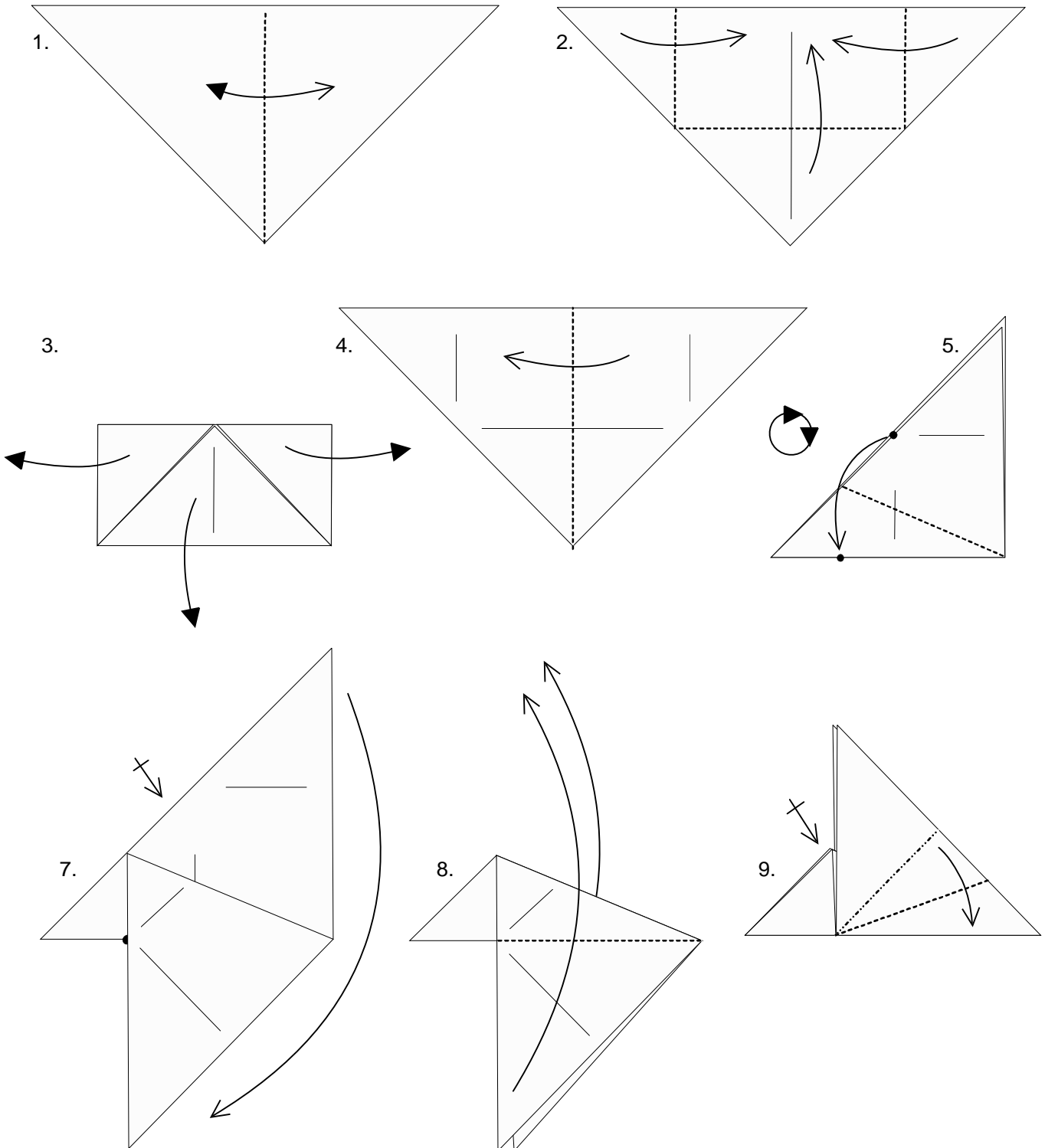

Diagrammed by J.C. Nolan - Sept. '94

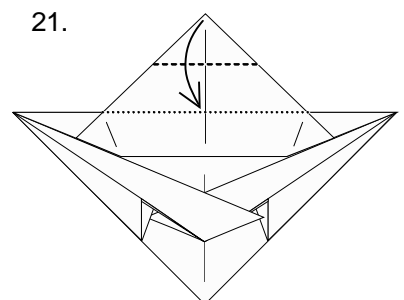
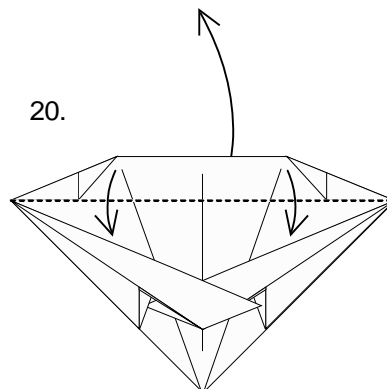
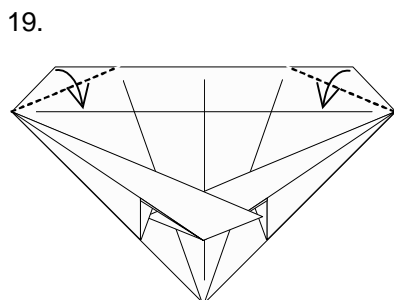
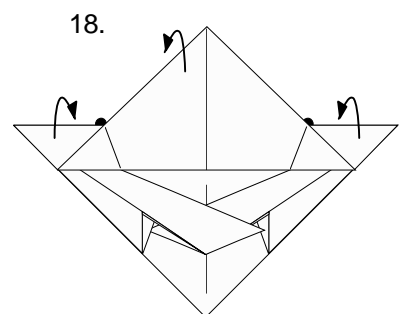
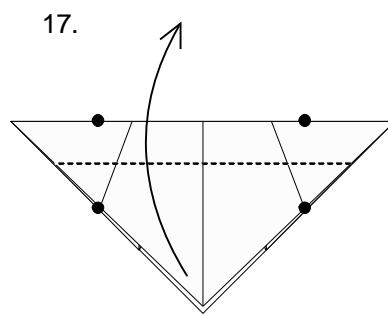
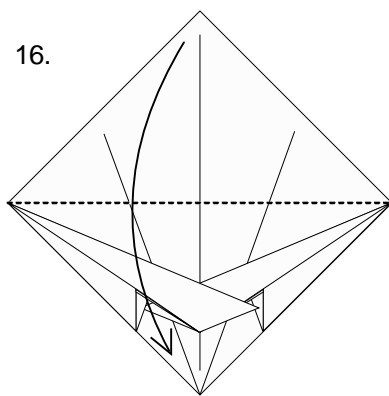
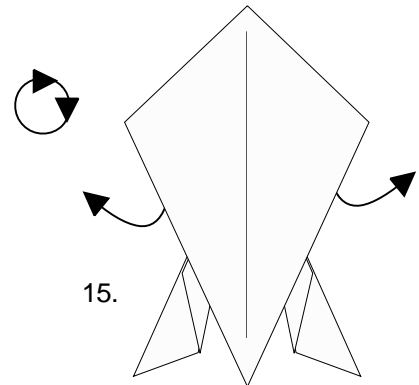
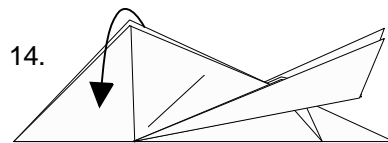
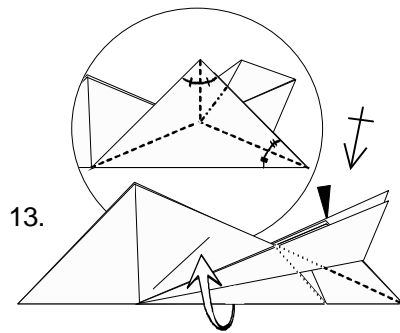
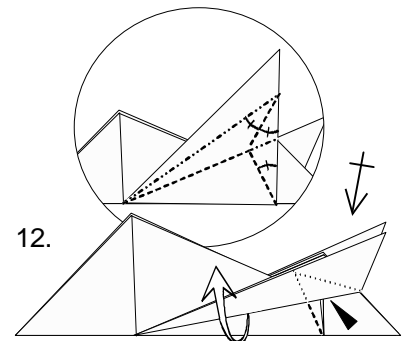
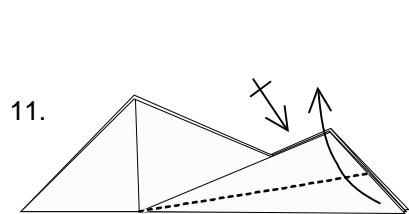
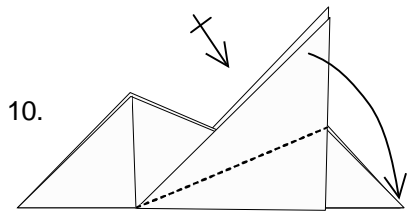

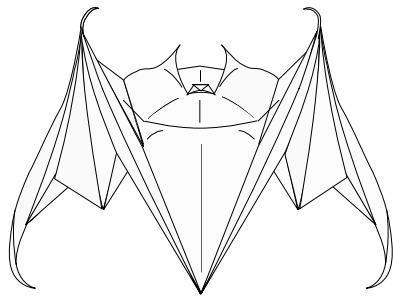
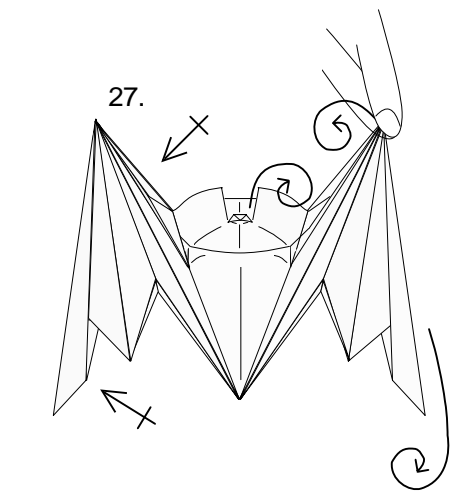
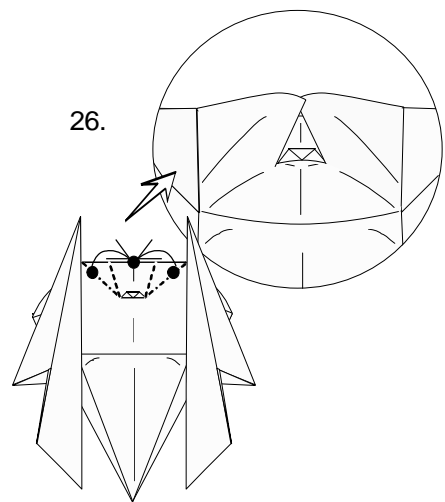
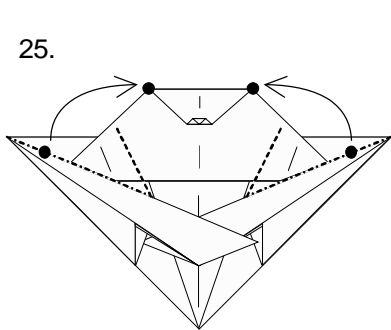
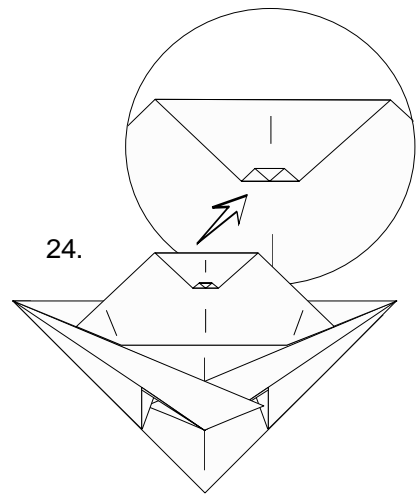
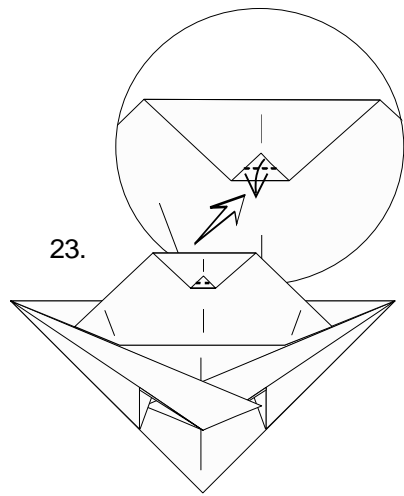
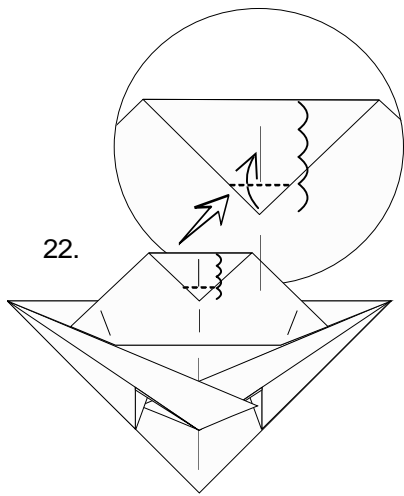

**Grumpy Bat**  
*(Taper Ears Inward)*

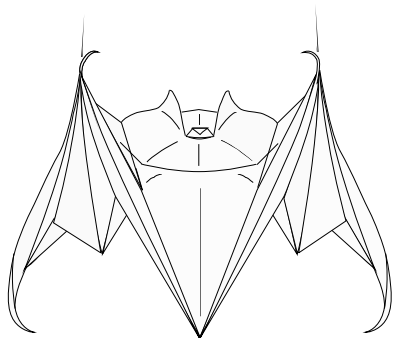

**Happy Bat**  
*(Original Version)*

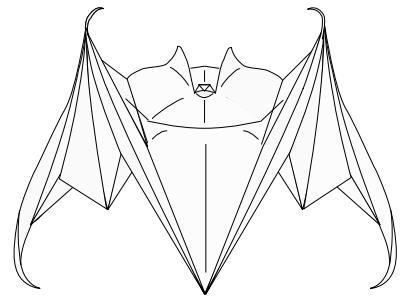

**Vocal Bat**  
*(Open Mouth)*

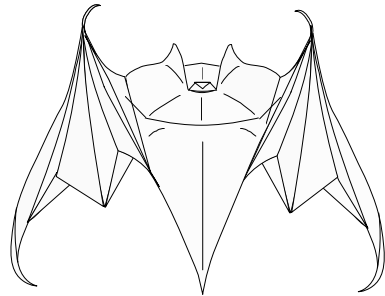

**Tapered Bat**  
*(Taper Bottom Inward)*

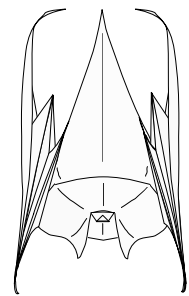

**Sleeping Bat**  
*(Taper Bottom, Invert & Compress)*