

PILOTE: \_\_\_\_\_

DATE ET LIEU : \_\_\_\_\_

**ACCROCHE**

- ELEVE
- MOYEN
- GLISSANTE

**SURFACE**

- PLANE
- MOYEN
- DEFONCE

**CONDITION**

- HERBE
- HUMIDE
- POUSSIERE

## SUSPENSION AVANT

OUVERTURE \_\_\_\_\_

DEBATEMENT  
AVANT \_\_\_\_\_

CAROSSAGE \_\_\_\_\_

GARDE AU SOL \_\_\_\_\_

- CHASSE
- 17°
  - 20°
  - 22°

- B.A.R
- 2.4 mm
  - 2.6 mm

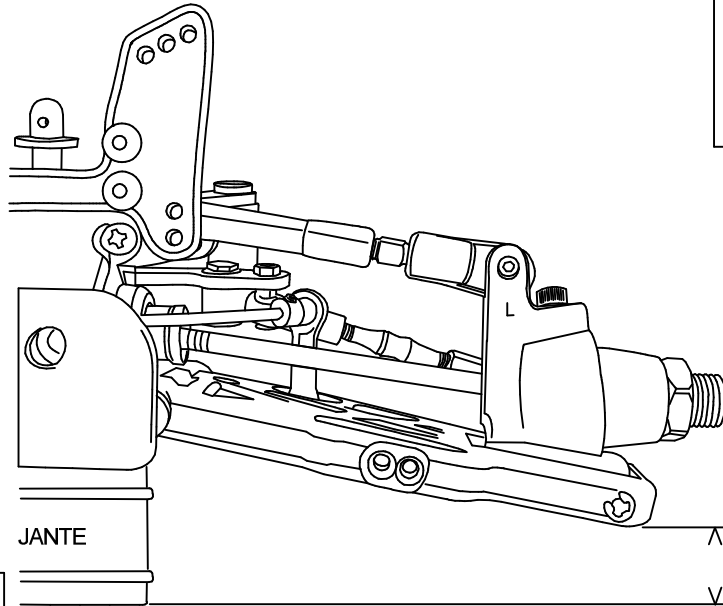

**BAR DE DIRECTION**

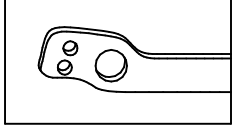

### AMORTISSEURS

HUILE \_\_\_\_\_  
PISTON \_\_\_\_\_  
RESSORTS \_\_\_\_\_

NOTES : \_\_\_\_\_  
\_\_\_\_\_  
\_\_\_\_\_

## SUSPENSION AVANT

PINCEMENT \_\_\_\_\_

DEBATEMENT  
ARRIERE \_\_\_\_\_

CAROSSAGE \_\_\_\_\_

GARDE AU SOL \_\_\_\_\_

- B.A.R  2.8 mm

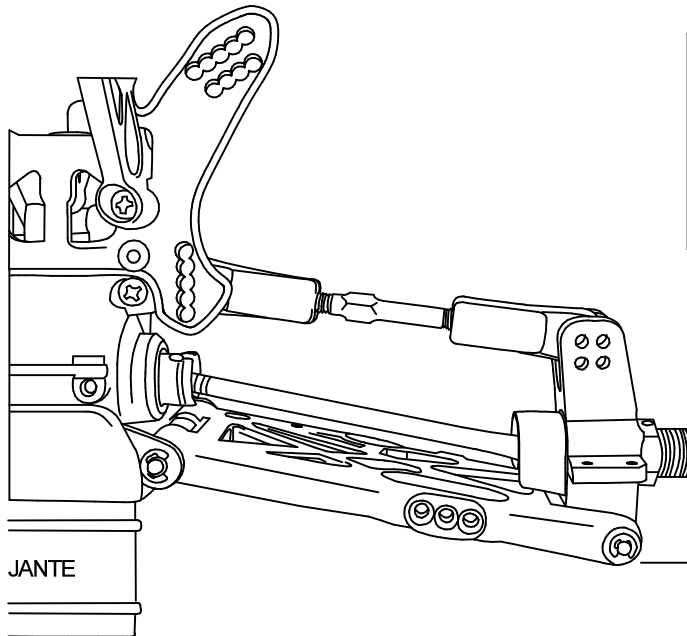

**AILERON**

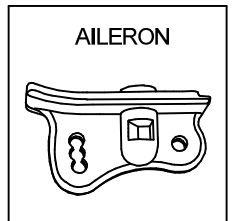

### AMORTISSEURS

HUILE \_\_\_\_\_  
PISTON \_\_\_\_\_  
RESSORTS \_\_\_\_\_

NOTES : \_\_\_\_\_  
\_\_\_\_\_  
\_\_\_\_\_

**DIFFERENTIEL** AVANT \_\_\_\_\_ NORMAL / TORSEN / SPIDER  
CENTRE \_\_\_\_\_ NORMAL / TORSEN / SPIDER  
ARRIERE \_\_\_\_\_ NORMAL / TORSEN / SPIDER

**PNEUS** AVANT TYPE \_\_\_\_\_ ARRIERE TYPE \_\_\_\_\_  
INSERT \_\_\_\_\_ INSERT \_\_\_\_\_

**MOTEUR** TYPE \_\_\_\_\_ ECHAPPEMENT/ACCORD \_\_\_\_\_  
BOUGIE \_\_\_\_\_ CARBURANT \_\_\_\_\_

**CLOCHE**  13 EMBRAYAGE \_\_\_\_\_  
 14 RESSORT \_\_\_\_\_  
 \_\_\_\_\_